

# L1/L2GPNRRKIT



## Portable Networked Re-Radiating Kit Technical Product Data

### Features

- Re-Radiating Amplifier with External Power Supply
  - 30 dB gain typical.
- Optional Kit Mounting Hardware
  - Re-Radiating Amplifier Mount available.
- Optional Variable Gain Amplifier
  - Adjustable gain from 1 dB to 26 dB.
- Optional Variable Gain Amplifier with LCD Screen
  - Adjustable gain from 1 dB to 30 dB.



### Description

The **L1/L2G Portable Networked Re-Radiating Kit (L1/L2GPNRRKIT)** is a re-radiating kit that is designed for deployments where a full L-band antenna is already in place. The L-band signal received by the previously installed roof antenna is amplified and re-radiated to GPS receivers inside of a denied space using the passive re-radiating antenna. The **L1/L2GPNRRKIT** consists of a passive re-radiating antenna and a re-radiating amplifier (**L1/L2GPNRRKAMP**) with an external power supply that powers the entire system. A cable from the roof antenna to the re-radiating kit is required and can be purchased separately.

In the standard Networked (Externally Powered) configuration, the re-radiating amplifier output (**J1**) is DC Blocked while the antenna port will receive the RF signal and pass the customer selected voltage (3.3 to 15 VDC). Custom gain, DC power, and connector configurations are available upon request.

### Use Cases

- To re-radiate signal indoors for GPS product testing.
- To maintain GPS signal for military vehicles parked indoors.
- To facilitate faster GPS signal acquisition for military aircraft inside a hangar.
- In combination with one of our splitter devices, to create a GPS distribution network.

# L1/L2GPNRRKIT



## Re-Radiating Antenna Electrical Specifications, TA=25°C

<u>Parameter</u>	<u>Notes</u>	<u>Min</u>	<u>Typ</u>	<u>Max</u>	<u>Unit</u>
<b>Frequency</b>	Re-Radiates all major GNSS frequencies.	1500 1150		1615 1290	MHz
<b>Axial Ratio</b>	Ratio between the major and minor axes of the polarization ellipse.			2.5	dB
<b>Peak Gain</b>	The Increase in signal power relative to an isotropic antenna source.			3	dBic
<b>GPS L1 Bandwidth</b>	Passband centered at GPS L1 frequency.		115		MHz
<b>GPS L2/L5 Bandwidth</b>	Passband centered at GPS L2/L5 frequency.		140		MHz
<b>Input SWR</b>	Input Standing Wave Ratio: S11 over the passband.		2.0:1		-
<b>Characteristic Impedance</b>	Input port matched to 50Ω.		50		Ω
<b>Polarization</b>					
<b>Right Hand Circular Polarization</b>					
Connector Options	<b>Connector Style</b>		<b>Charge</b>		
	Type TNC-female		No Charge		

# L1/L2GPNRRKIT



## Re-Radiating Amplifier Electrical Specifications, TA=25°C

### General Specification

Parameter	Notes	Min	Typ	Max	Unit
Frequency Range	Covers all major GNSS constellations.	1.1		1.7	GHz
Characteristic Impedance	Input and output ports matched to 50Ω.		50		Ω
Req. DC Input V.	Operating Voltage Range.	3.3		15	VDC
Current Draw	Typical current consumption.		36	40	mA

### GPS L1 & L2 RF Specification <sup>(1)</sup>

Parameter	Notes	Min	Typ	Max	Unit
Gain	The relative increase in signal power provided by the amplifier.	29	30	31	dB
Input SWR	Input Standing Wave Ratio: S11			2.0:1	-
Output SWR	Output Standing Wave Ratio: S22		1.8:1	2.0:1	-
Noise Figure	The increase in noise power relative to an ideal amplifier.		L1:2.0 L2:4.25		dB
Band Gain Flatness	The difference in loss or gain between the L1 and L2 frequencies.		0.5	1	dB
Group Delay	The transmit time for the signal passing through the device.		L1:1.5 L2:2.1		ns
Reverse Isolation	Attenuation applied signals traveling backwards through the amplifier: S12.		L1: -55 L2: -60		dB
Input P1dB	The 1dB compression point.		L1: -21.5 L2: -23		dBm
3rd Order Intercept	Third-order intercept point at L1.		-14		dBm

(1): Performance is slightly reduced around GPS L5. If working on sensitive L5 applications, please request performance data.

External Power Options (Networked Option)		
Source Voltage Options	Voltage Input	Style
	110VAC	Transformer (ITA Type A Wall Mount)
	220VAC	Transformer (ITA Type C Wall Mount)
	240VAC (United Kingdom)	Transformer (ITA Type G Wall Mount)
	Customer Supplied DC 9-32 VDC	MIL-DTL-5015 10SL Two-Pin DC Connector (Includes Mate)
Output Voltage Options <sup>(2)</sup>	DC Voltage Out	Max Current out For Corresponding Vout
	3.3 V	110mA
	5V	130mA
	9V	140mA
	12V	180mA
	15V	220mA
	Custom	Custom
Standard DC Configuration without External Power Option		
All Ports Pass DC		
Standard DC Configuration with any External Power Option (AC/DC or Military DC)		
J1 Port DC Blocked with 200Ω load standard		
Antenna Port is DC Pass		
Connector Options	Connector Style	Charge
	Type N-female	No Charge
	Type SMA-female	No Charge
	Type TNC-female	No Charge
	Type BNC-female	No Charge
	Other	Contact GPS Networking

(2): With Network Option, any RF port (input or output) can be specified to Pass DC or Block DC

# L1/L2GPNRRKIT



## Part Number Configuration

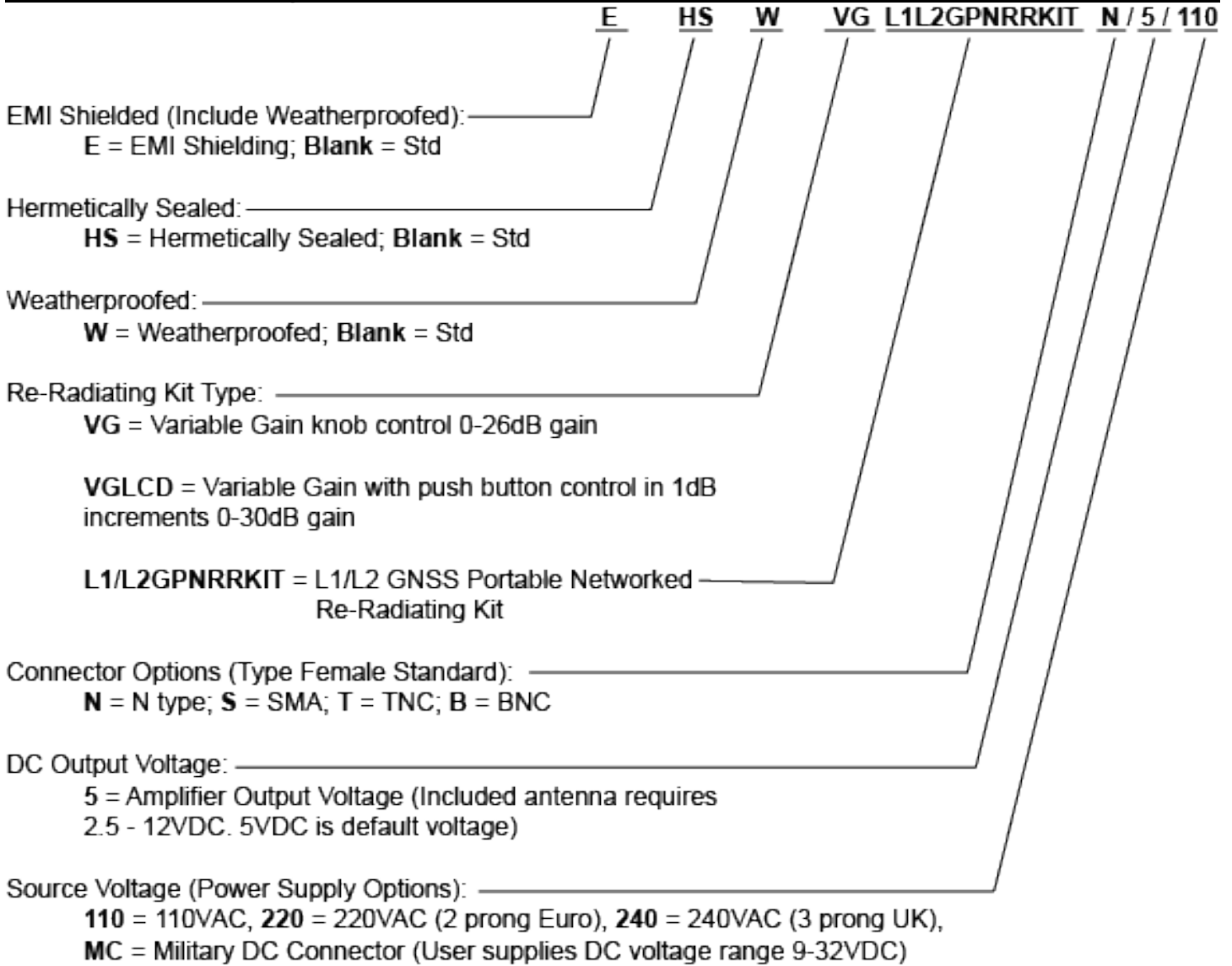

(Military DC Mating Connector is included standard with the MC power option).

When no external power supply option (AC or DC) is selected, Output 1/J1 is Pass DC Standard.  
When external power supply option is selected, all outputs are DC blocked standard.

Contact GPS Networking Technical Support at 1-800-463-3063 or [salestech@gpsnetworking.com](mailto:salestech@gpsnetworking.com) for any questions regarding non-standard configurations and corresponding part numbers.

# L1/L2GPNRRKIT



## Performance

### L1/L2GPNRRKAMP (Standard Gain)

Each L1/L2GPNRRKAMP ships with a test sheet that verifies critical performance characteristics, such as gain, input VSWR, and amplitude balance; a typical VNA test sheet is shown below.

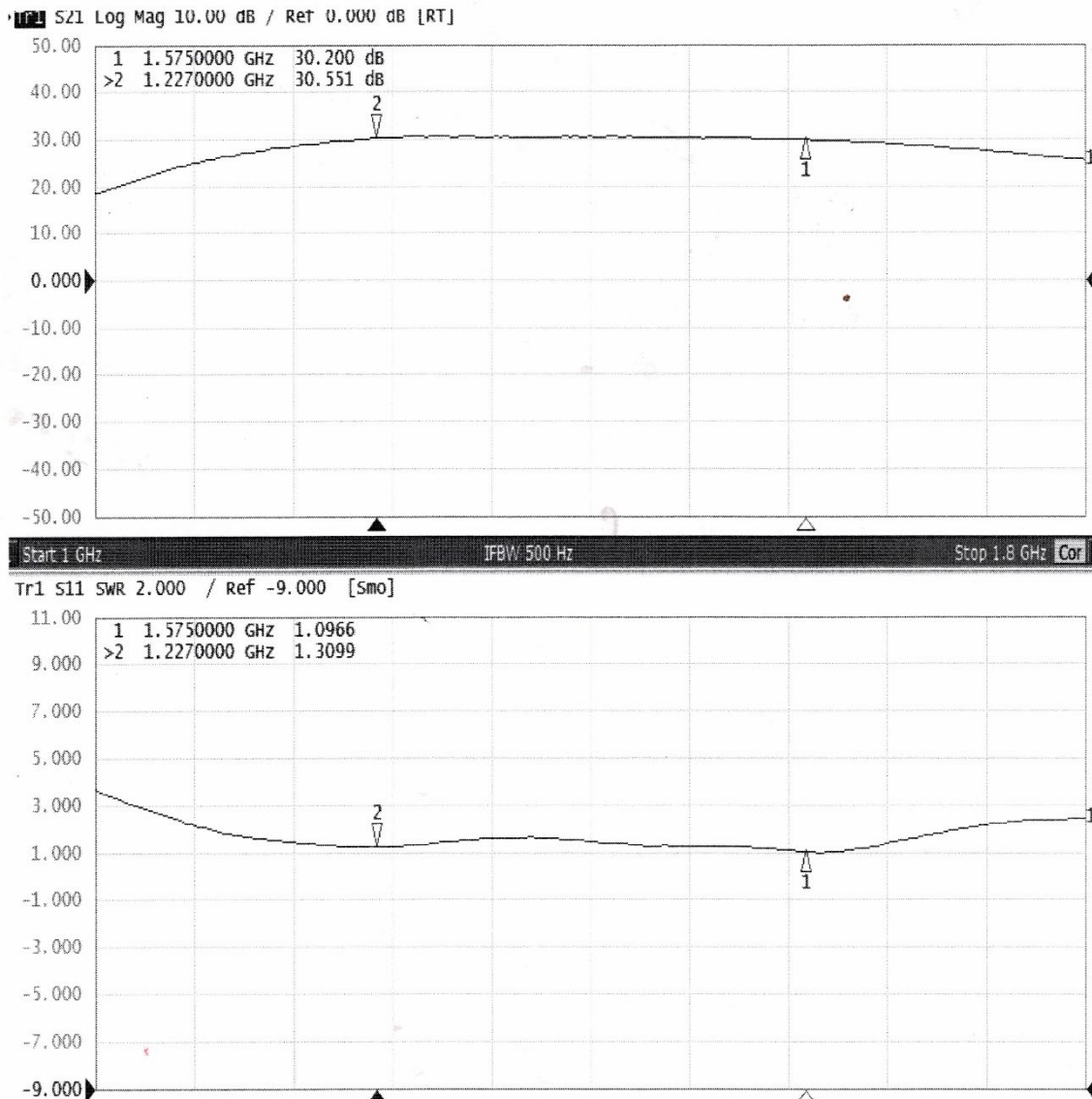

# Mechanical

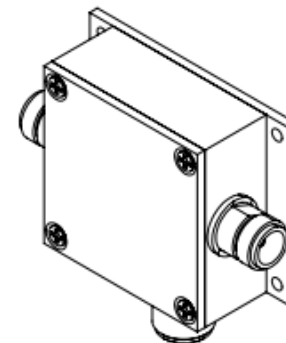
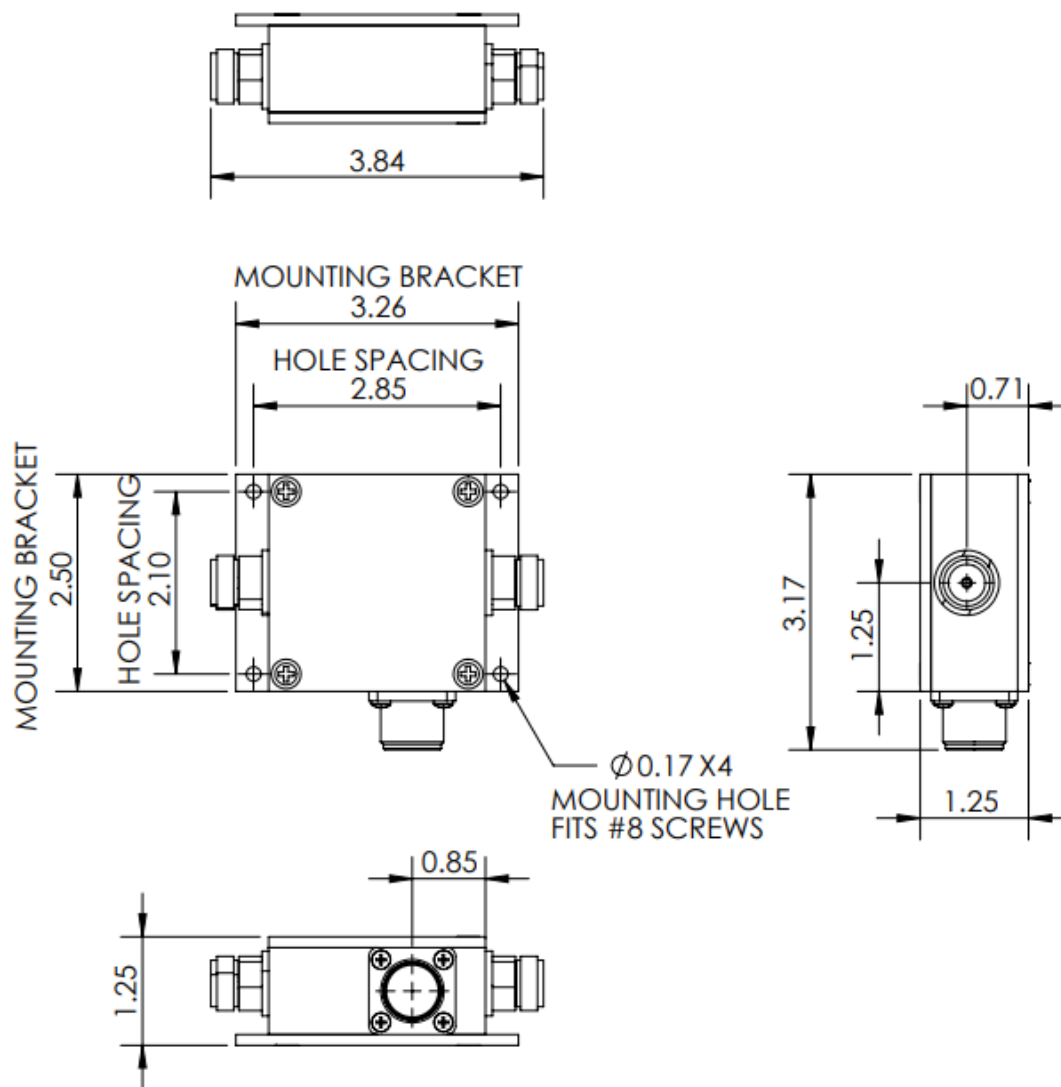

**Mechanical**  
**Dimensions:**  
 Depth: 1.3"  
 Width: Body: 2.5"  
       Baseplate: 3.25"  
 Height: 2.5"  
 Dimensions listed above do not include connectors  
 Weight: 9.6oz (272g) MAX  
 Maximum weight is with female N-connector option  
 Weight will vary by connector type  
 Operating Temperature Range: -57°C to +87°C  
 Housing and Baseplate Finish: Electroless Nickel Plated (MIL-C-26074C, Class 1 0.0001-0.0003 MAX)  
 Lid Finish: Anodize, Type II, Class 2, Black, per MIL-A-8625

Female N connectors shown, other options available  
 MC - Military DC connector shown, other options available  
 EMI shielding may increase dimension by 0.02 inches per axis



PNRRKAMP-N/5/MC			
Portable Networked Re-Radiating Kit Amplifier			
07-26-21	MM	Scale: 1:2	Rev: 1
Sheet 1 of 1		Units are inches and degrees	

Tolerances:  
 X ± 0.030  
 XX ± 0.015  
 XXX ± 0.005  
 Angle ± 1°

Contact us at [salestech@gpsnetworking.com](mailto:salestech@gpsnetworking.com) for 3D models or CAD drawings.

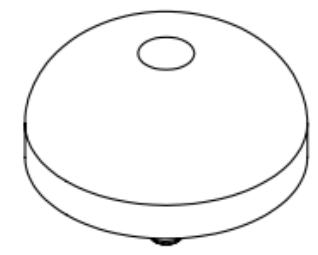
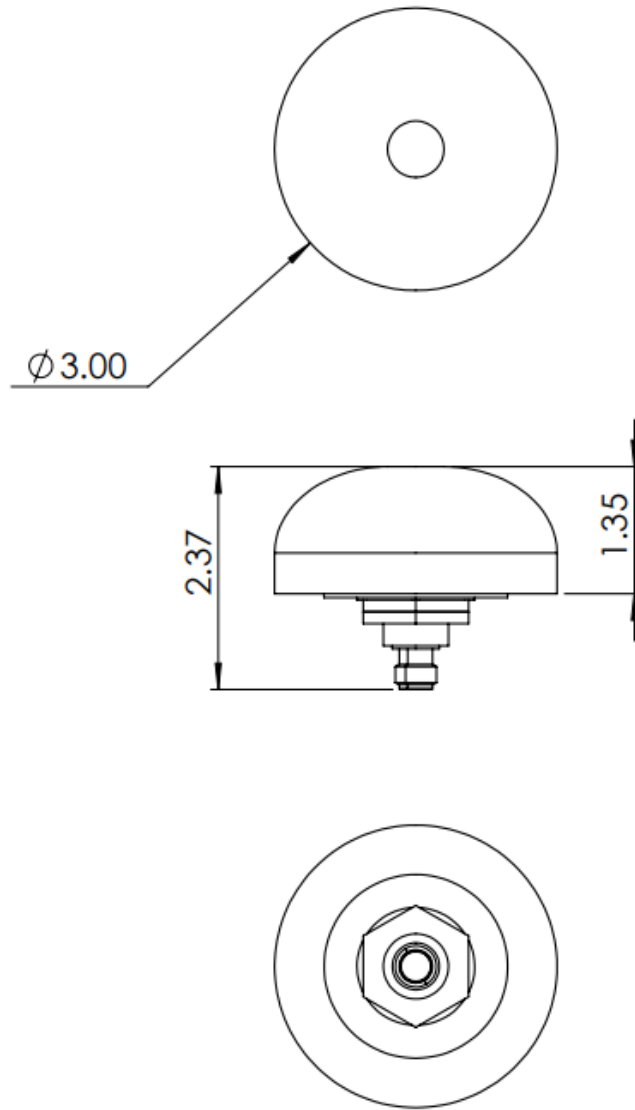

Mechanical  
 Dimensions:  
 Diameter: 3.0"  
 Height: 1.4"  
 Weight: 7.4oz (210g) MAX  
 Environmental Rating: AAR  
 Compliant  
 IP Rating: IP 67

Female TNC connector required, use adapter for mating

 373 E. Industrial Blvd. Pueblo West, CO 81007	L1/L2GRRKPA-T				Tolerances: X $\pm$ 0.030 XX $\pm$ 0.015 XXX $\pm$ 0.005 Angle $\pm$ 1°
	Multi GNSS Passive High Performance Antenna				
1-8-2021	NW	Scale: 1:2	Rev: 1	Sheet 1 of 1	Units are inches and degrees