

HNRKIT

Hangar Networked Re-Radiating Kit Technical Product Data

Features

- High Gain Amplified Roof Antenna
 - Provides 38 dB gain via internal LNA.
- Re-Radiating Amplifier with External Power Supply
 - 30 dB gain typical.
- Optional Kit Mounting Hardware
 - Roof Antenna Mount & Re-Radiating Amplifier Mount available.
- Optional Re-Radiating Variable Gain Amplifier
 - Adjustable gain from 0 dB to 26 dB.
- Optional Variable Gain with LCD Screen
 - Adjustable gain from 1 dB to 30 dB.



Please note that the pictured L1RAMB and WRUMT mounts are not included with the HNRKIT

Description

The GPS Hangar Networked **Re-Radiating Kit (HNRKIT)** is a re-radiating kit that is designed for hangars or other large spaces without obstructions to restrict and attenuate the signal. The GPS L1 signal received by the included roof antenna is amplified and re-radiated to GPS receivers inside of a denied space using the passive re-radiating antenna. The HNRKIT consists of an active roof antenna, a passive re-radiating antenna, and a re-radiating amplifier (HNRKAMP) with an external power supply that powers the entire system. A cable from the roof antenna to the re-radiating kit is required and can be purchased separately.

In the standard Networked (Externally Powered) configuration, the re-radiating amplifier output (**J1**) is DC Blocked while the antenna port provides 5 VDC to power the roof antenna. Custom gain, DC power, and connector configurations are available upon request.

Use Cases

- To re-radiate signal indoors for GPS product testing.
- To maintain GPS signal for military vehicles parked indoors.
- To facilitate faster GPS signal acquisition for military aircraft inside a hangar.
- In combination with one of our splitter devices, to create a GPS distribution network.

HNRRKIT



Roof Antenna Electrical Specifications, TA=25°C

Parameter	Notes	Min	Typ	Max	Unit
Frequency	Receives and amplifies GPS L1 frequency.		1.575		GHz
Gain	The relative increase in signal power provided by the internal LNA.	30	38		dB
Bandwidth	Passband centers at GPS L1 frequency.		10		MHz
Filtering	Out of band rejection +/-50MHz from GPS L1 frequency.		-60		dB
Noise Figure	The increase in noise power relative to an ideal amplifier.		1.8		dB
Output SWR	Output Standing Wave Ratio: S22 at L1.			1.5:1	-
Characteristic Impedance	Output port matched to 50Ω.		50		Ω
Req. DC Input V.	Operating Voltage Range.	4.5	5.0	5.5	VDC
Current Draw	Typical current consumption.		20	27	mA
Polarization					
Right Hand Circular Polarization					
Connector Options	Connector Style	Charge			
	Type N-female	No Charge			

Re-Radiating Antenna Electrical Specifications, TA=25°C

Parameter	Notes	Min	Typ	Max	Unit
Frequency	Re-Radiates GPS L1 frequency.	1.572	1.575	1.578	GHz
Axial Ratio	The ratio between the major and minor axes of the polarization ellipse.			3	dB
Peak Gain	The increase in signal power relative to an isotropic antenna source.			4	dBic
Bandwidth	Passband centers at GPS L1 frequency.	20			MHz
Input SWR	Input Standing Wave Ratio: S11 at L1.			1.5:1	-
Characteristic Impedance	Input port matched to 50Ω.		50		Ω
Polarization					
Right Hand Circular Polarization					
Connector Options	Connector Style	Charge			
	Type SMA-female	No Charge			

HNRRKIT



Re-Radiating Amplifier Electrical Specifications, TA=25°C

General Specification

Parameter	Notes	Min	Typ	Max	Unit
Frequency Range	Covers all major GNSS constellations.	1.1		1.7	GHz
Characteristic Impedance	Input and output ports matched to 50Ω.		50		Ω
Req. DC Input V.	Operating Voltage Range.	3.3		15	VDC
Current Draw	Typical current consumption.		36	40	mA

GPS L1 & L2 RF Specification ⁽¹⁾

Parameter	Notes	Min	Typ	Max	Unit
Gain	The relative increase in signal power provided by the amplifier.	29	30	31	dB
Input SWR	Input Standing Wave Ratio: S11			2.0:1	-
Output SWR	Output Standing Wave Ratio: S22		1.8:1	2.0:1	-
Noise Figure	The increase in noise power relative to an ideal amplifier.		L1:2.0 L2:4.25		dB
Band Gain Flatness	The difference in loss or gain between the L1 and L2 frequencies.		0.5	1.0	dB
Group Delay	The transmit time for the signal passing through the device.		L1:1.5 L2:2.1		ns
Reverse Isolation	Attenuation applied signals traveling backwards through the amplifier: S12.		L1: -55 L2: -60		dB
Input P1dB	The 1dB compression point.		L1: -21.5 L2: -23		dBm
3rd Order Intercept	Third-order intercept point at L1.		-13		dBm

(1): Performance is slightly reduced around GPS L5. If working on sensitive L5 applications, please request performance data.

External Power Options (Networked Option)		
Source Voltage Options	Voltage Input	Style
	110VAC	Transformer (ITA Type A Wall Mount)
	220VAC	Transformer (ITA Type C Wall Mount)
	240VAC (United Kingdom)	Transformer (ITA Type G Wall Mount)
	Customer Supplied DC 9-32 VDC	MIL-DTL-5015 10SL Two-Pin DC Connector (Includes Mate)
Output Voltage Options ⁽²⁾	DC Voltage Out	Max Current out For Corresponding Vout
	3.3 V	110mA
	5V	130mA
	9V	140mA
	12V	180mA
	15V	220mA
	Custom	Custom
Standard DC Configuration without External Power Option		
All Ports Pass DC		
Standard DC Configuration with any External Power Option (AC/DC or Military DC)		
J1 Port DC Blocked with 200Ω load standard		
Antenna Port is DC Pass		
Connector Options	Connector Style	Charge
	Type N-female	No Charge
	Type SMA-female	No Charge
	Type TNC-female	No Charge
	Type BNC-female	No Charge
	Other	Contact GPS Networking

(2): With Network Option, any RF port (input or output) can be specified to Pass DC or Block DC

HNRRKIT

Part Number Configuration

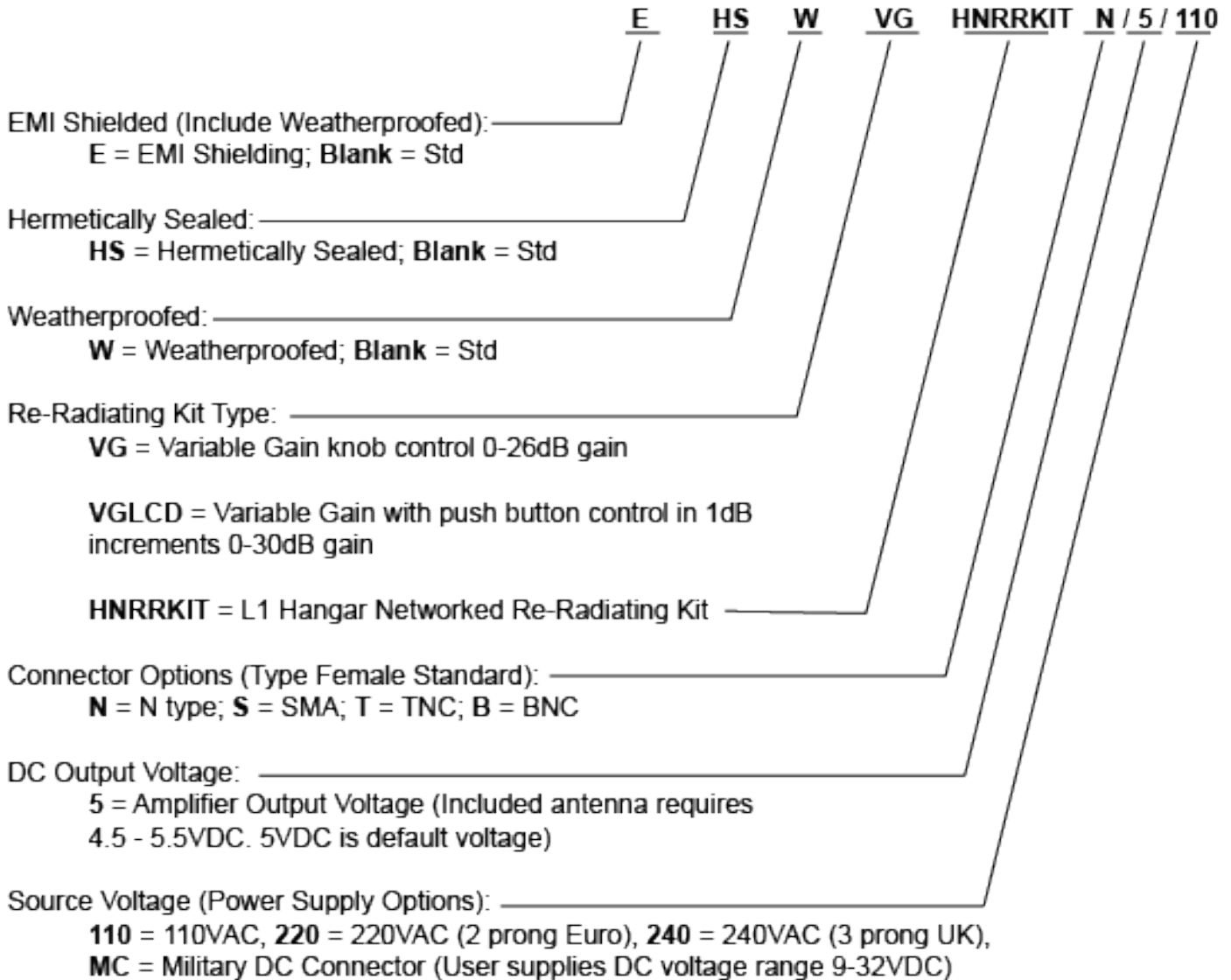

(Military DC Mating Connector is included standard with the MC power option).

When no external power supply option (AC or DC) is selected, Output 1/J1 is Pass DC Standard.
 When external power supply option is selected, all outputs are DC blocked standard.

Contact GPS Networking Technical Support at 1-800-463-3063 or salestech@gpsnetworking.com for any questions regarding non-standard configurations and corresponding part numbers.

HNRRKIT



Performance

HNRRKAMP (Standard Gain)

Each HNRRKAMP ships with a test sheet that verifies critical performance characteristics, such as gain, input VSWR, and amplitude balance; a typical VNA test sheet is shown below.

GPS NETWORKING Test Data

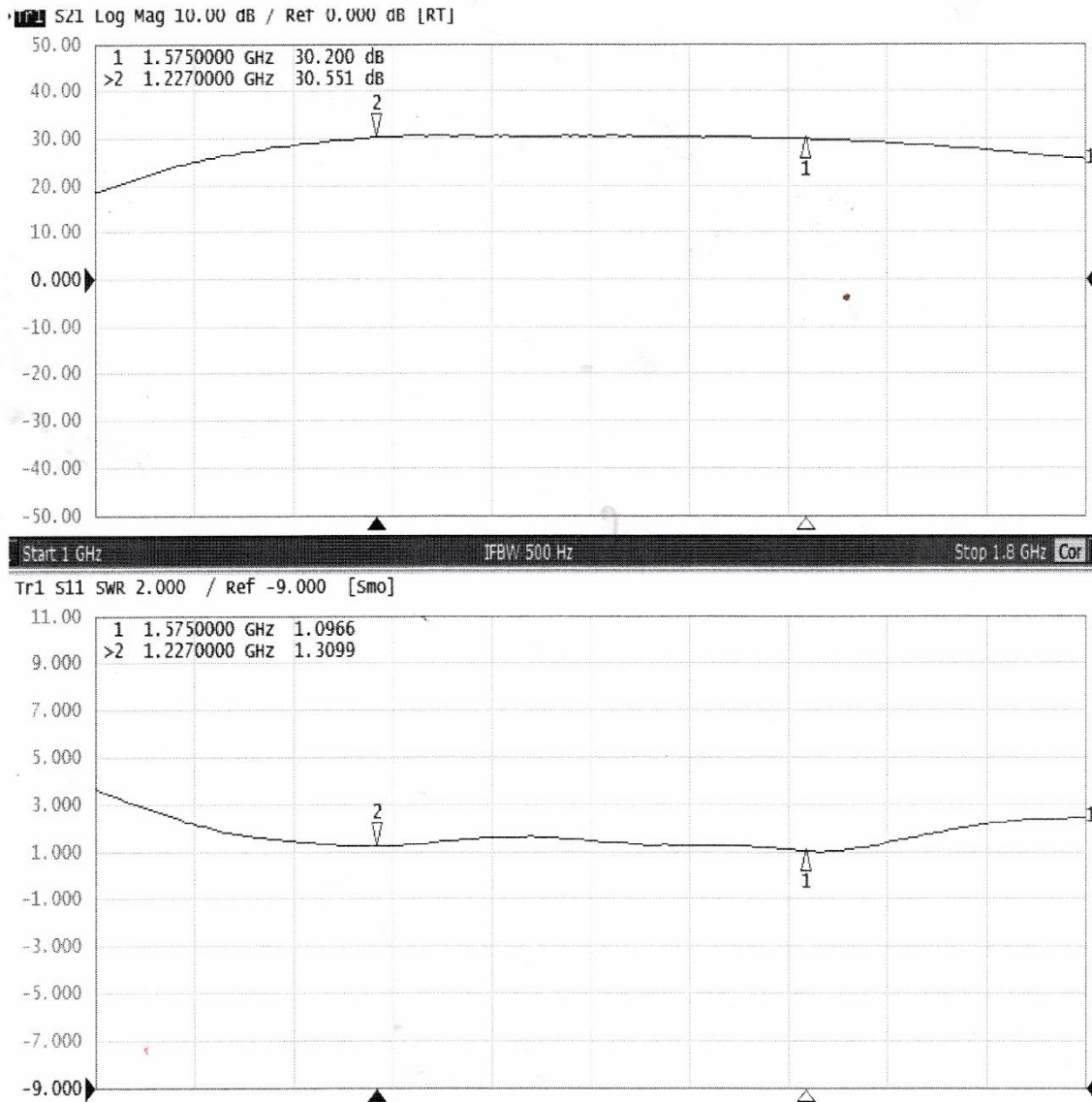

Mechanical

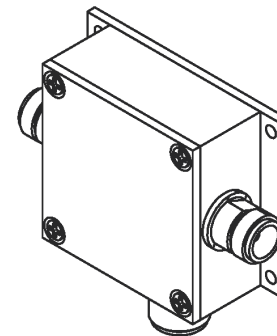
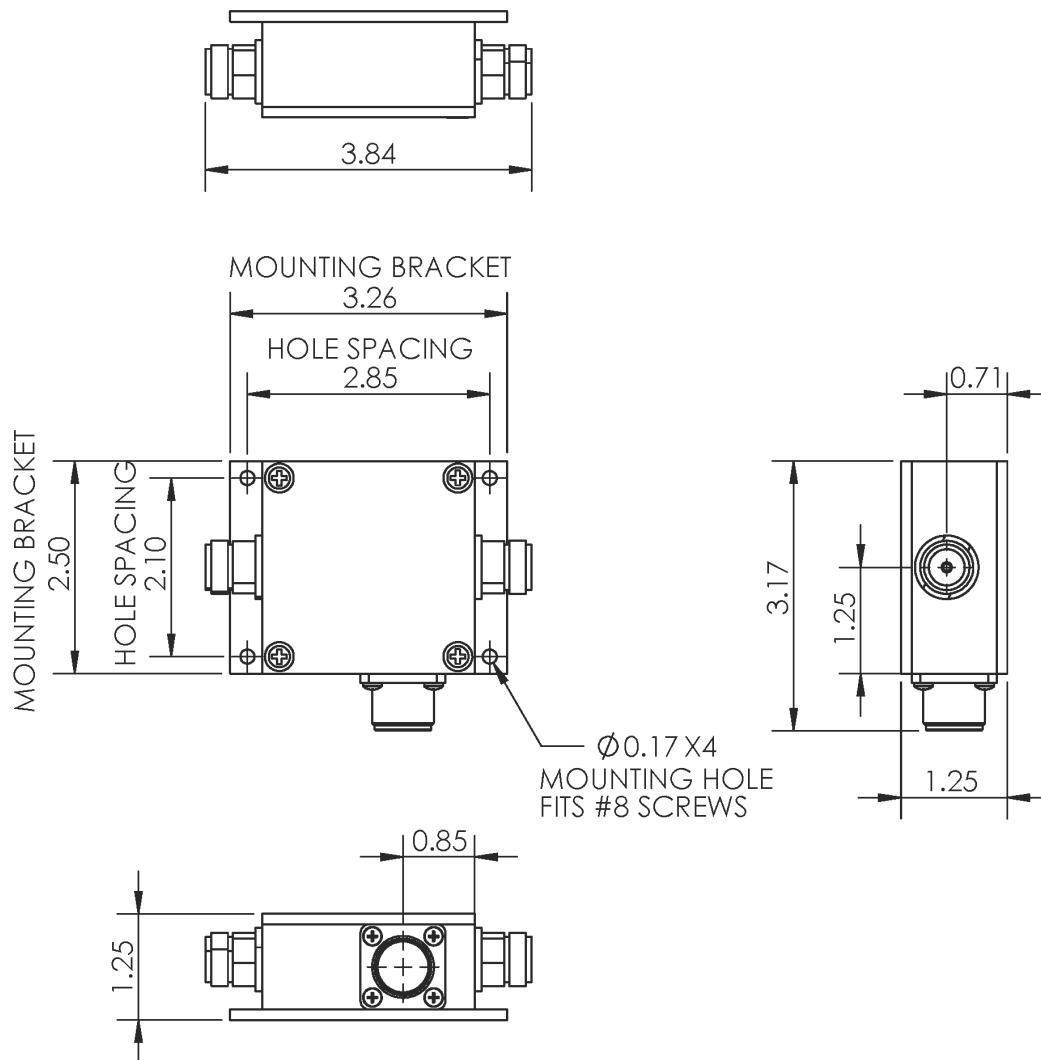

Mechanical
 Dimensions:
 Depth: 1.3"
 Width: Body: 2.5"
 Baseplate: 3.25"
 Height: 2.5"
 Dimensions listed above
 do not include connectors
 Weight: 9.6oz (272g) MAX
 Maximum weight is with female
 N-connector option
 Weight will vary by connector type
 Operating Temperature Range:
 -57°C to +87°C
 Housing and Baseplate Finish:
 Electroless Nickel Plated
 (MIL-C-26074C, Class 1
 0.0001-0.0003 MAX)
 Lid Finish: Anodize, Type II,
 Class 2, Black, per MIL-A-8625

Female N connectors shown, other options available
 MC - Military DC connector shown, other options available
 EMI shielding may increase dimension by 0.02 inches per axis



HNRKAMP-N/5/MC

Hangar Networked Re-Radiating Kit Amplifier

Tolerances:
 X ± 0.030
 XX ± 0.015
 XXX ± 0.005
 Angle ± 1°

12-21-2020	NW	Scale: 1:2	Rev: 1	Sheet 1 of 1	Units are inches and degrees
------------	----	------------	--------	--------------	------------------------------

Contact us at salestech@gpsnetworking.com for 3D models or CAD drawings.

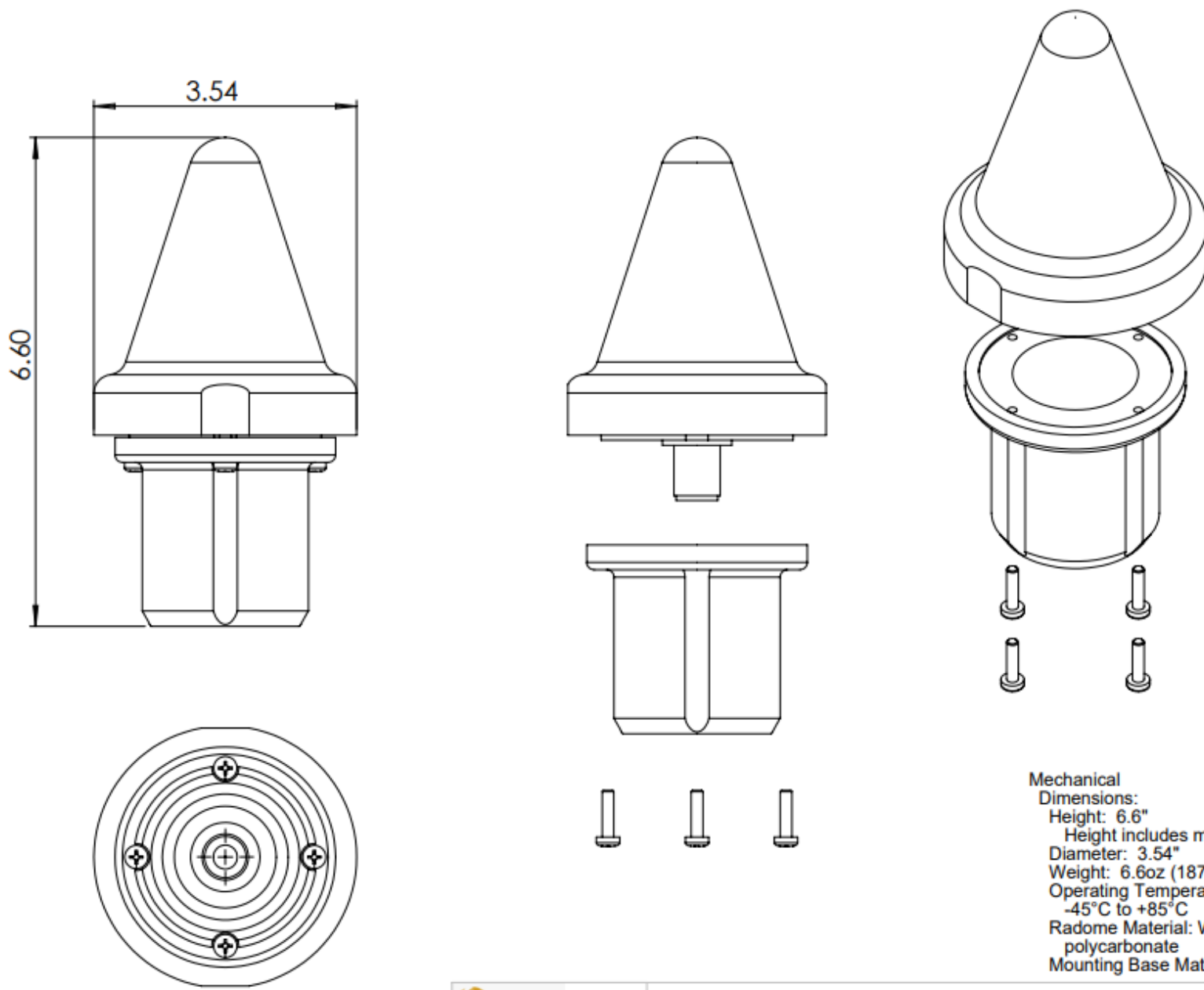

Mechanical
 Dimensions:
 Height: 6.6"
 Height includes mounting base
 Diameter: 3.54"
 Weight: 6.6oz (187g) MAX
 Operating Temperature Range:
 -45°C to +85°C
 Radome Material: White polycarbonate
 Mounting Base Material: Aluminum

Female N connector required, use adapter for mating



L1GPSA-N
 L1 GPS Active Antenna

Tolerances:
 X ± 0.030
 XX ± 0.015
 XXX ± 0.005
 Angle ± 1°

04-14-2021	MM	Scale: 1:2	Rev: 1	Sheet 1 of 1	Units are inches and degrees
------------	----	------------	--------	--------------	------------------------------

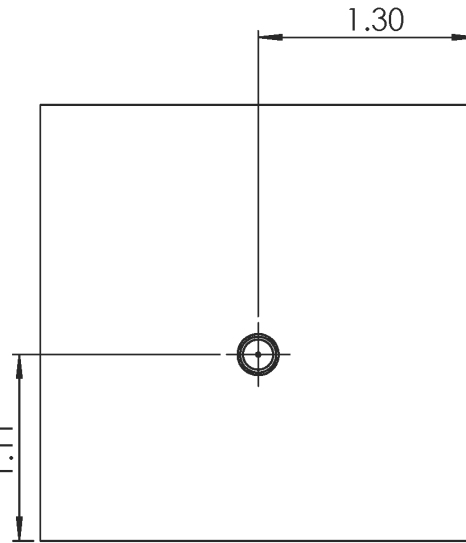
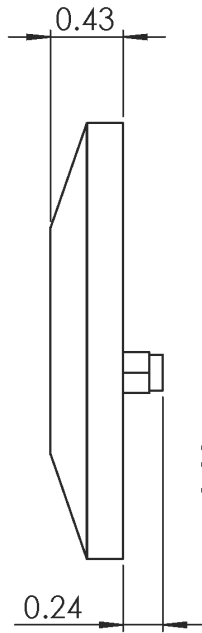
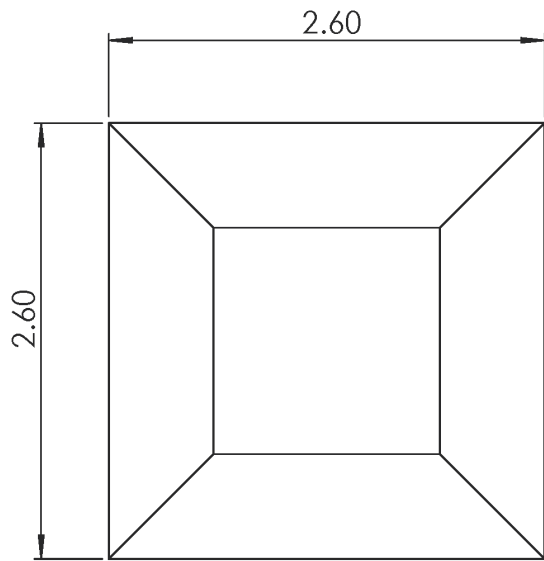
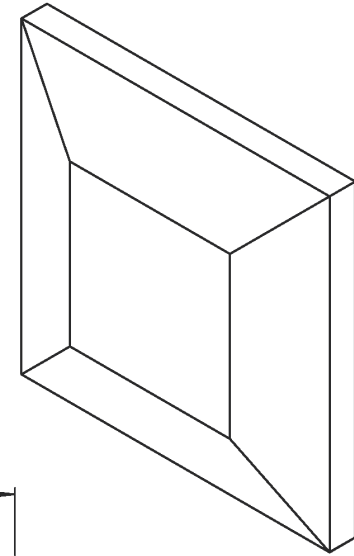
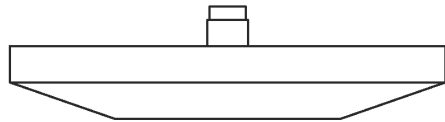

Mechanical
 Dimensions:
 Depth: 0.67"
 Width: 2.6"
 Height: 2.6"
 Weight: 1.7oz (48g) MAX
 Operating Temperature Range:
 -40°C to +85°C
 Housing Material: ABS

Female SMA connector required, use adapter for mating

 373 E. Industrial Blvd. Pueblo West, CO 81007	L1RRKPA-S				Tolerances: X ± 0.030 XX ± 0.015 XXX ± 0.005 Angle ± 1°
	L1 Re-Radiating Kit Passive Antenna				
12-21-2020	NW	Scale: 1:1	Rev: 1	Sheet 1 of 1	Units are inches and degrees