

## GPS Indoor Testing Solution Technical Product Data

### Features

- High Gain Amplified Roof Antenna
  - Provides 38 dB gain via internal LNA.
- Variable Gain Re-Radiating Amplifier with LCD Screen and External Power Supply
  - Push button adjustable gain from 1 dB to 30 dB.
- Mounting Hardware Kit
  - Roof Antenna Mount & Re-Radiating Amplifier Mount included.
- 50ft of LMR400 Low Loss Cable
  - Custom lengths available at additional cost.



### Description

The **GPS Indoor Testing Solution (GPS-ITS)** comes with everything you need to build a complete re-radiating system that can re-radiate the GPS L1 signal indoors. The GPS L1 signal received by the roof antenna is amplified and re-radiated to GPS receivers indoors, eliminating the need to attach receivers directly to the roof antenna. The GPS-ITS consists of an active roof antenna, a passive re-radiating antenna, a roof antenna mount (L1RAMB), a re-radiating amplifier mount (WRUMT), 50ft of LMR400 cable, and a variable gain re-radiating amplifier (NVGLCDLA30RPDC) with an external power supply that powers the entire system. With 50ft of LMR400 low loss coax cable connecting the roof antenna to the re-radiating amplifier, the GPS-ITS will transmit the GPS signal indoors to receivers up to 200 feet away.

In the standard Networked (Externally Powered) configuration, the re-radiating amplifier output (**J1**) is DC Blocked.

### Use Cases

- Re-radiates the L1 signal indoors for GPS product testing.
- Saves time and money by keeping military aircraft hangared during navigation system maintenance.
- Keeps navigation receivers “warm” for rapid military deployment.
- In combination with one of our splitter devices to create a GPS distribution network.

# GPS-ITS



## Roof Antenna Electrical Specifications, TA=25°C

Parameter	Notes	Min	Typ	Max	Unit
Frequency	Receives and amplifies GPS L1 frequency.		1.575		GHz
Gain	The relative increase in signal power provided by the internal LNA.		38		dB
Bandwidth	Passband centers at GPS L1 frequency.		10		MHz
Filtering	Out of band rejection +/-50MHz from GPS L1 frequency.		-60		dB
Noise Figure	The increase in noise power relative to an ideal amplifier.		1.8		dB
Output SWR	Output Standing Wave Ratio: S22 at L1.			1.5:1	-
Characteristic Impedance	Output port matched to 50Ω.		50		Ω
Req. DC Input V.	Operating Voltage Range.	4.5	5	5.5	VDC
Current Draw	Typical current consumption.		20	27	mA
<b>Polarization</b>					
<b>Right Hand Circular Polarization</b>					
Connector Options	Connector Style	Charge			
	Type N-female	No Charge			

## Re-Radiating Antenna Electrical Specifications, TA=25°C

Parameter	Notes	Min	Typ	Max	Unit
Frequency	Re-Radiates GPS L1 frequency.	1.572	1.575	1.578	GHz
Axial Ratio	Ratio between the major and minor axes of the polarization ellipse.			3	dB
Peak Gain	The Increase in signal power relative to an isotropic antenna source.			4	dBic
Bandwidth	Passband centers at GPS L1 frequency.	20			MHz
Input SWR	Input Standing Wave Ratio: S11 at L1.			1.5:1	-
Characteristic Impedance	Input port matched to 50Ω.		50		Ω
<b>Polarization</b>					
<b>Right Hand Circular Polarization</b>					
Connector Options	Connector Style	Charge			
	Type SMA-female	No Charge			

# GPS-ITS



## Re-Radiating Amplifier Electrical Specifications, TA=25°C

### General Specification

Parameter	Notes	Min	Typ	Max	Unit
Frequency Range	Covers all major GNSS constellations.	1.1		1.7	GHz
Characteristic Impedance	Input and output ports matched to 50Ω.		50		Ω
Reverse Isolation	Attenuation applied signals traveling backwards through the amplifier: S12.		-60		dB
Req. DC Input V.	Operating Voltage Range.	3.3		15	VDC
Current Draw	Typical current consumption.		42		mA

### GPS L1 & L2 RF Specification <sup>(1)</sup>

Parameter	Notes	Min	Typ	Max	Unit
Min Gain	The relative increase in signal power provided by the amplifier when set to the minimum gain level.	-1	0	1	dB
Max Gain	The relative increase in signal power provided by the amplifier when set to the maximum gain level.	29	30	31	dB
Input SWR	Input Standing Wave Ratio: S11 at L1 and L2			2.0:1	-
Output SWR	Output Standing Wave Ratio: S22 at L1 and L2		1.65:1	2.0:1	-
Noise Figure Min Gain	The increase in noise power relative to an ideal amplifier.		L1:4.4 L2:6.25		dB
Noise Figure Max Gain	The increase in noise power relative to an ideal amplifier.		L1:1.9 L2:4.66		dB
Band Gain Flatness	The difference in loss or gain between the L1 and L2 frequencies.		0.5	1.0	dB
Input P1dB	The 1dB compression point at L1.		-22.9		dBm
3rd Order Intercept	Third-order intercept point at L1.		-14		dBm

(1): Performance is slightly reduced around GPS L5. If working on sensitive L5 applications, please request performance data.

External Power Options (Networked Option)		
Source Voltage Options	Voltage Input	Style
	110VAC	Transformer (ITA Type A Wall Mount)
	220VAC	Transformer (ITA Type C Wall Mount)
	240VAC (United Kingdom)	Transformer (ITA Type G Wall Mount)
	Customer Supplied DC 9-32 VDC	MIL-DTL-5015 10SL Two-Pin DC Connector (Includes Mate)
Output Voltage Options <sup>(2)</sup>	DC Voltage Out	Max Current out For Corresponding Vout
	3.3 V	110mA
	5V	130mA
	9V	140mA
	12V	180mA
	15V	220mA
	Custom	Custom
Standard DC Configuration with any External Power Option (AC/DC or Military DC)		
<b>J1 Port DC Blocked with 200Ω load standard</b>		
<b>Antenna Port is DC Pass</b>		
Connector Options	Connector Style	Charge
	Type N-female	No Charge

(2): With Network Option, any RF port (input or output) can be specified to Pass DC or Block DC

# GPS-ITS



## Part Number Configuration

---

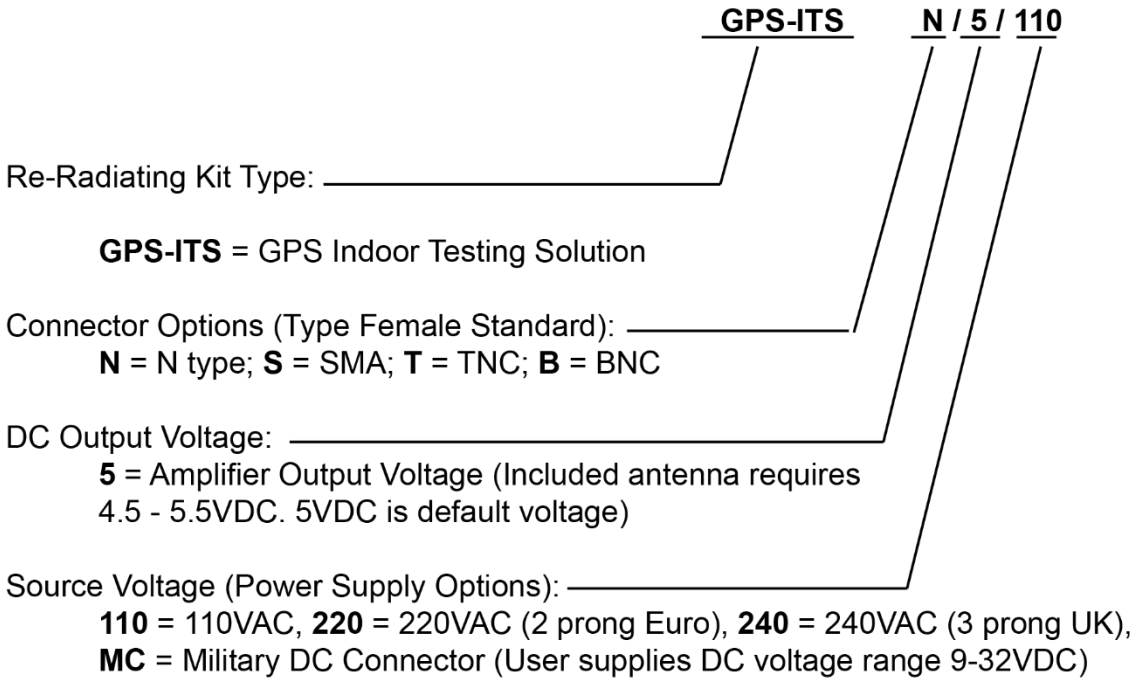

(Military DC Mating Connector is included standard with the MC power option).

When no external power supply option (AC or DC) is selected, Output 1/J1 is Pass DC Standard.  
When external power supply option is selected, all outputs are DC blocked standard.

Contact GPS Networking Technical Support at 1-800-463-3063 or [salestech@gpsnetworking.com](mailto:salestech@gpsnetworking.com) for any questions regarding non-standard configurations and corresponding part numbers.

# GPS-ITS

## Performance



NVGLCDLA30RPDC (Standard Gain at 30dB Setting)

Each GPS-ITS kit ships with a test sheet for the included NVGLCDLA30RPDC amplifier. This test sheet verifies critical performance characteristics, such as gain, input VSWR, and amplitude balance; a typical VNA test sheet is shown below.

### GPS NETWORKING Test Data

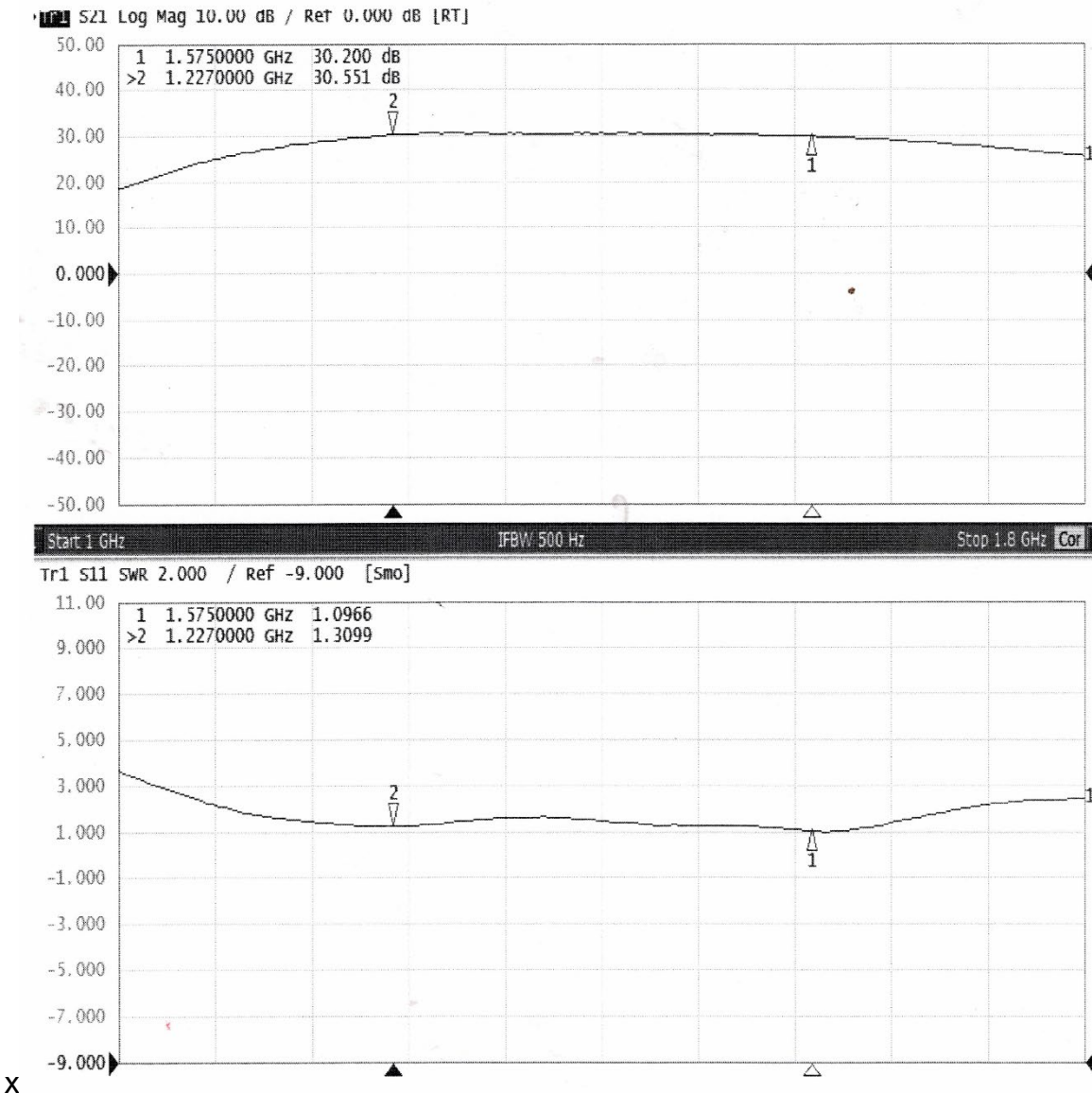

# Mechanical

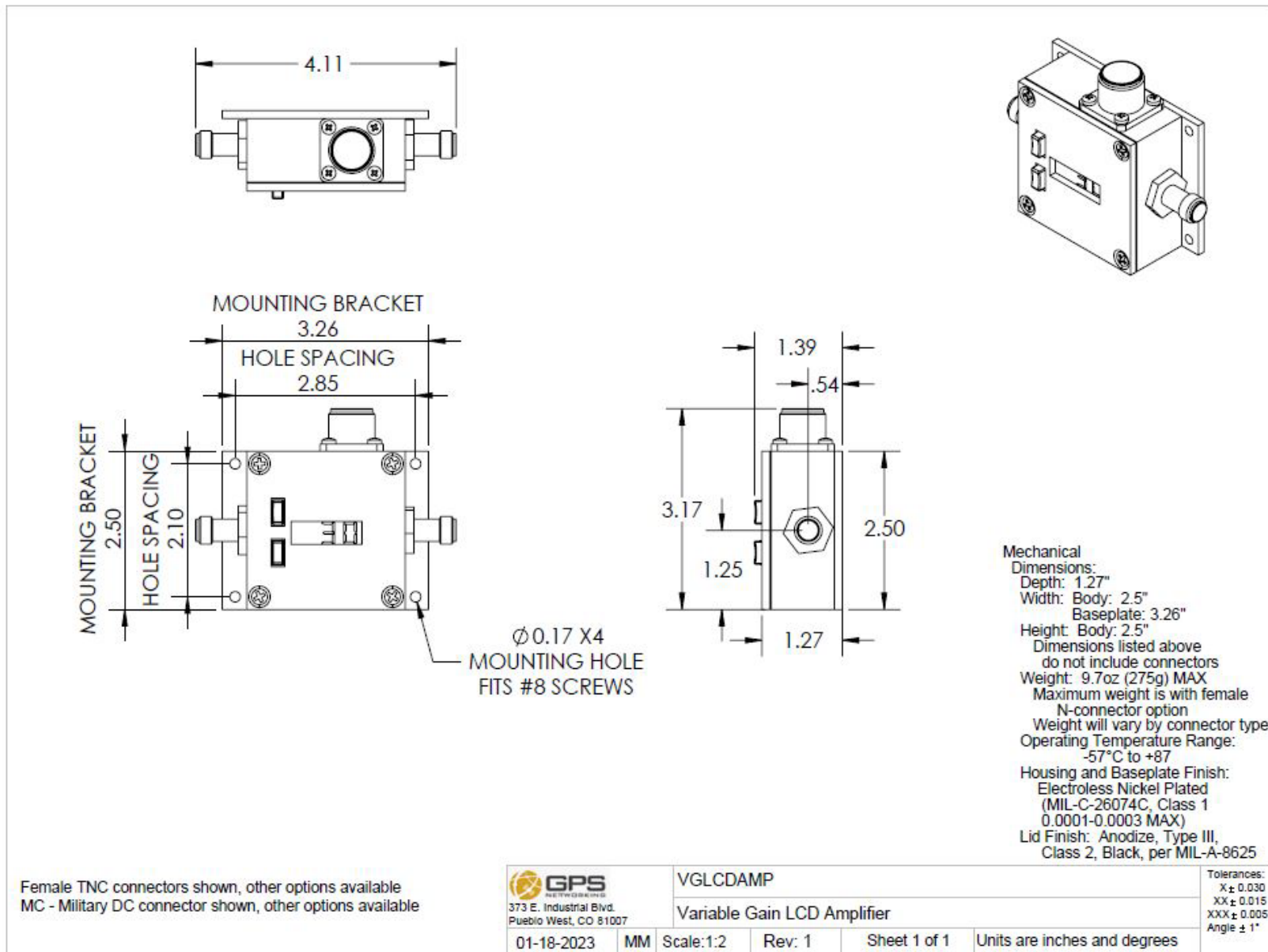

Contact us at [salestech@gpsnetworking.com](mailto:salestech@gpsnetworking.com) for 3D models or CAD drawings.

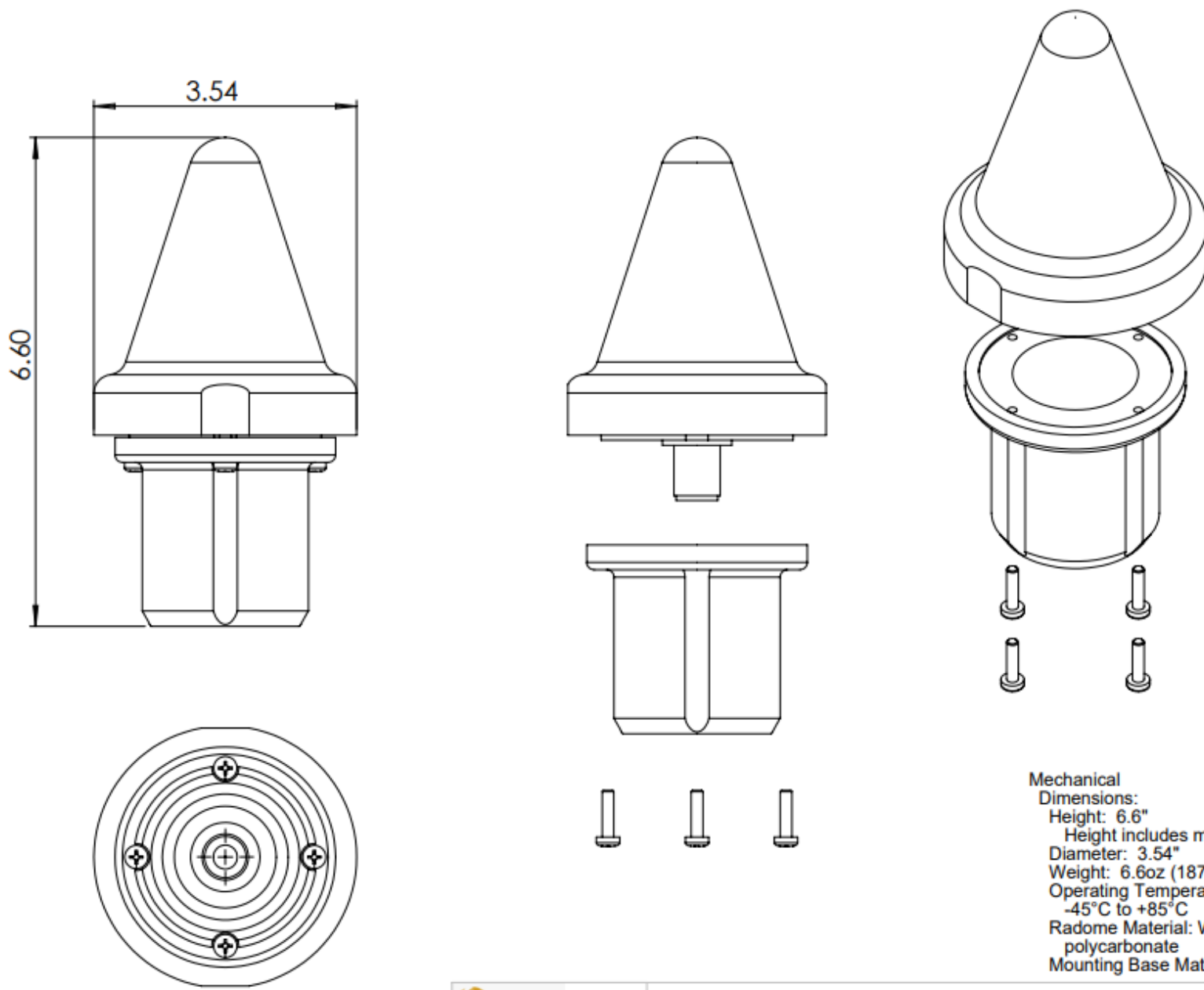

**Mechanical Dimensions:**  
 Height: 6.6"  
 Height includes mounting base  
 Diameter: 3.54"  
 Weight: 6.6oz (187g) MAX  
 Operating Temperature Range:  
 -45°C to +85°C  
 Radome Material: White polycarbonate  
 Mounting Base Material: Aluminum

 **GPS NETWORKING**  
 373 E. Industrial Blvd.  
 Pueblo West, CO 81007

**L1GPSA-N**  
**L1 GPS Active Antenna**

Tolerances:  
 X ± 0.030  
 XX ± 0.015  
 XXX ± 0.005  
 Angle ± 1°

Female N connector required, use adapter for mating

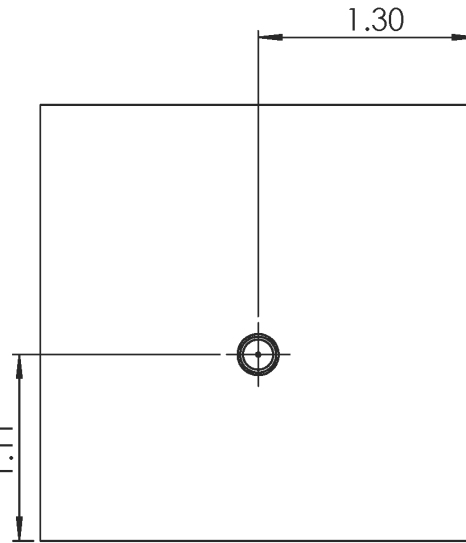
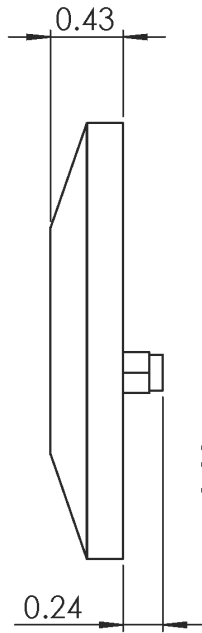
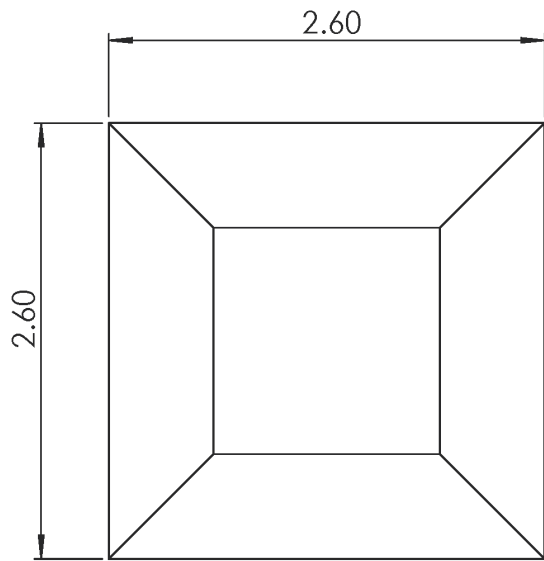
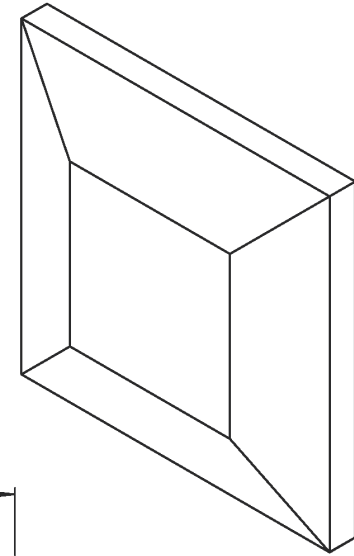
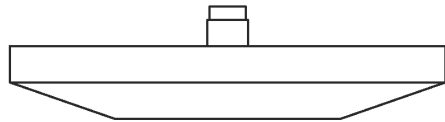

Mechanical  
 Dimensions:  
 Depth: 0.67"  
 Width: 2.6"  
 Height: 2.6"  
 Weight: 1.7oz (48g) MAX  
 Operating Temperature Range:  
 -40°C to +85°C  
 Housing Material: ABS

Female SMA connector required, use adapter for mating

 373 E. Industrial Blvd. Pueblo West, CO 81007	L1RRKPA-S				Tolerances: X ± 0.030 XX ± 0.015 XXX ± 0.005 Angle ± 1°
	L1 Re-Radiating Kit Passive Antenna				
12-21-2020	NW	Scale: 1:1	Rev: 1	Sheet 1 of 1	Units are inches and degrees



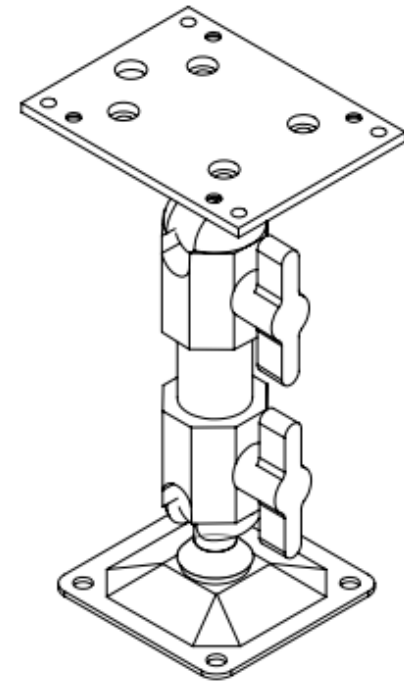
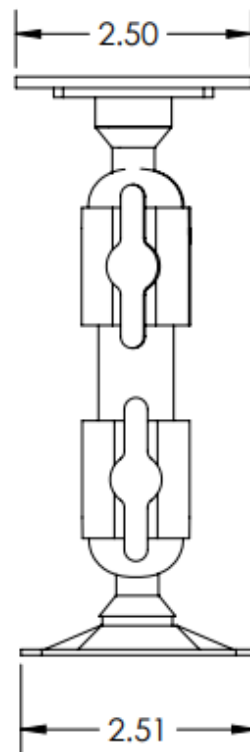
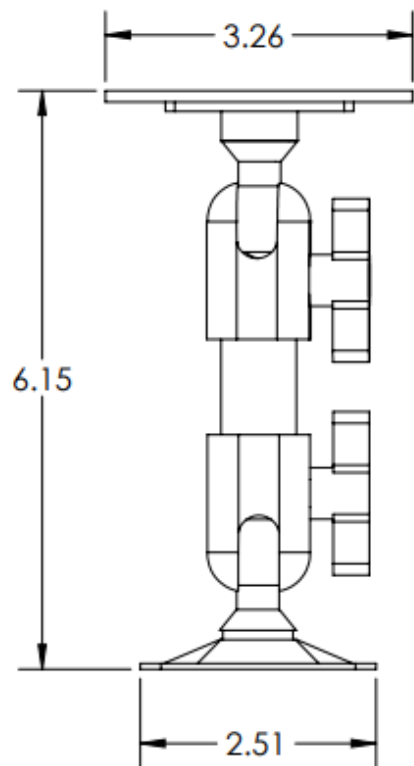

Mechanical  
 Dimensions:  
 Depth: 2.51"  
 Width: Top Plate: 3.26"  
 Baseplate: 2.51"  
 Height: 6.15"  
 Weight: 13.3oz (377g) MAX  
 Operating Temperature Range:  
 -57°C to +87  
 Materials: Aluminum  
 Zinc  
 Steel

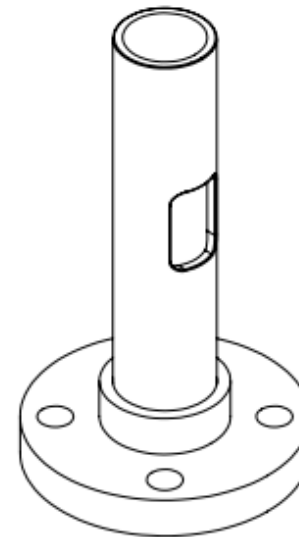
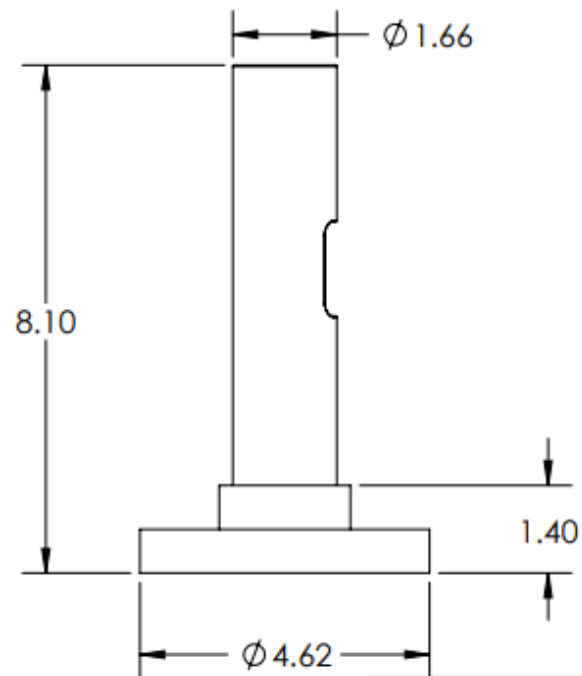
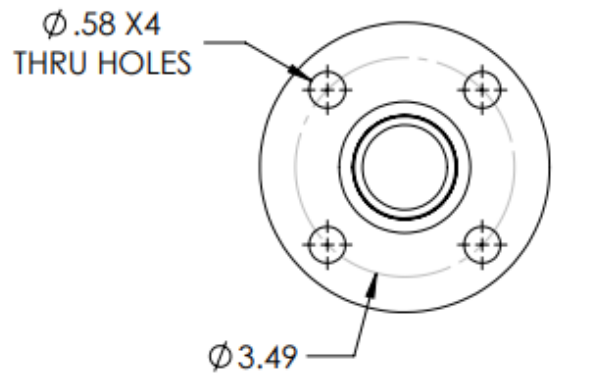

Mechanical  
 Dimensions:  
 Width: Body: 1.66"  
           Mounting Flange: 4.62"  
 Height: 8.10"  
 Weight: 13.8oz (390g) MAX  
 Material: PVC



L1RAMB

L1GPSA-N Roof Antenna Mounting Bracket

Tolerances:  
 X ± 0.030  
 XX ± 0.015  
 XXX ± 0.005  
 Angle ± 1°

04-13-2021

MM

Scale:1:3

Rev: 1

Sheet 1 of 1

Units are inches and degrees