



# ***RMALDCBS1X16***

## Technical Product Data

### Features

- **Extremely Flat Group Delay**  
Less than 1ns variation
- **High Isolation Option**  
>35dB of isolation between adjacent output ports
- **Phase Matched Outputs**  
Phase (J1 – J2) < 1.0°

### Description

The RMALDCBS1X16 GPS Rack Mount Amplified Splitter is a one input, sixteen output device. The frequency response covers the GPS L1 & L2 bands with excellent gain flatness. In the normal configuration, the splitter is powered by a transformer that supplies power to the splitter's amplifier and roof antenna. The outputs are DC loaded with 200Ω resistors to simulate the antenna current draw. Product is ideal for timing and testing applications where the GPS carrier signal is required by up to 16 GPS devices simultaneously.

### Electrical Specifications, $T_A = 25^{\circ}\text{C}$

Parameter	Conditions	Min	Typ	Max	Units
Freq. Range	Ant – Any Output, Unused Outputs - 50Ω	1.1		1.7	GHz
In/Out Imped.	Ant, J1, J2, J3, J4, J5, J6, J7, J8		50		Ω
Gain	Ant – Any Output, Unused Outputs - 50Ω	13	14.5	16.5	dB
Gain High Isolation	Ant – Any Output, Unused Outputs - 50Ω	-1.0	0.0	1.0	dB
Input SWR	All ports - 50Ω			2.0:1	-
Output SWR	All ports - 50Ω			1.3:1	-
Noise Figure	Normal Config., Ant – Any Output, Unused Outputs - 50Ω		3.8	4.3	dB
Gain Flatness	L1 – L2   ; Ant – Any Output, Unused Outputs - 50Ω		0.5	1	dB
Amplitude Balance	J1 – J2   ; Ant – Any Output, Unused Outputs - 50Ω			0.5	dB
Phase Balance	Phase (J1 – J2) ; Ant – Any Output, Unused Outputs - 50Ω			1.0	deg
Isolation	Hi Isolation Config, Adjacent Ports, Ant - 50Ω (see plots)	35			dB
Group delay Flatness	$\tau_{d,max} - \tau_{d,min}$ : Ant – J1, J2 - 50Ω ; Ant – J2, J1 - 50Ω			1	ns
Current	Amplifier Current Draw, All ports - 50Ω			15	mA

## Available Options

<b>Network Power Supply</b>		
Source Voltage Options	VOLTAGE INPUT	STYLE
	110VAC	Transformer (Wall Mount)
	220 VAC	Transformer (Wall Mount)
	240 VAC (United Kingdom)	Transformer (Wall Mount)
	Customer Supplied DC 9-32 VDC	Military Style Connector
Output Voltage Options <sup>(1)</sup>	DC VOLTAGE OUT	MAX CURRENT OUT FOR CORRESPONDING Vout <sup>(2)</sup>
	5 V	110mA
	7.5V	130mA
	9V	140mA
	12V	170mA
	15V	210mA
	Custom	TDB
<b>Output Port Isolation Options</b>		
High Isolation Option	High Isolation, 35dB min. Output Port – to – Output Port	
<b>Pass/Block DC Options</b>		
DC Blocked <sup>(1)</sup>	Jx (x=1...16) are DC blocked, Pass DC to ANT.	
<b>RF Connector Options</b>		
Connector Options	CONNECTOR STYLE	CHARGE
	Type N, TNC, SMA and BNC	NC

(1) With Network Option, any RF port (input or output) can be DC blocked or can pass the network DC voltage.

(2) TA = +50°C. Assuming Source of 110V or 220V Wall Mount Transformer. In general, maximum output current can be determined by:

$$I_{out} \leq 2.9 / (V_{sourceDC} - V_{out}) \text{ A}$$

## Part Number

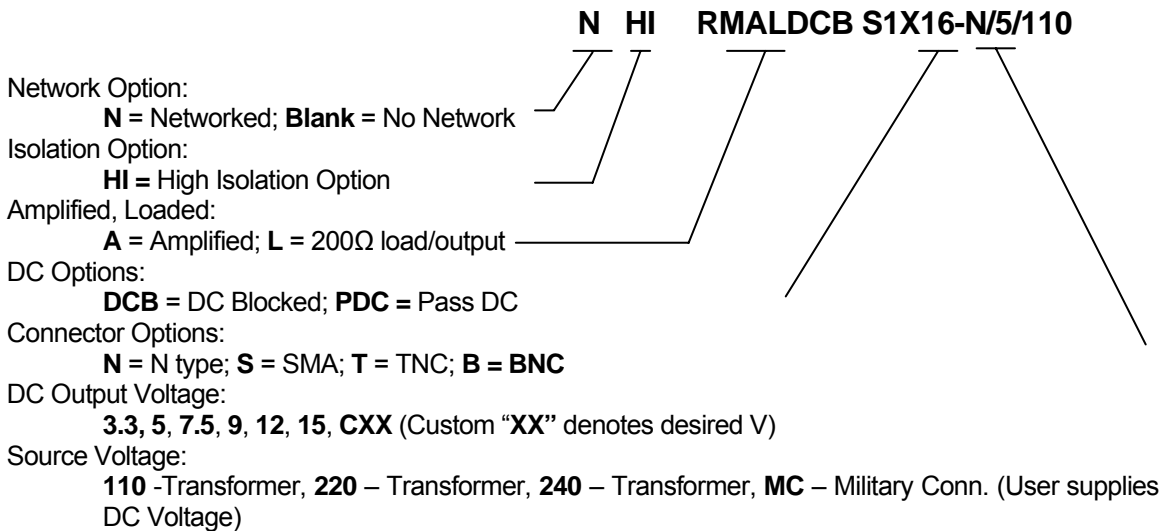

## Mechanical

Dimensions:            Height: 5.4"  
                                 Length: 18.0"  
                                 Width: 17.0"

Weight:                13.6 lbs.

Operating Temp. Range: -40° to + 75°C